

Flash Writer (AF200) Instruction Manual

Contents

To Ensure Safety Use of Flash Writer
Making the Most of AF200
Flash Writer
What is Flash Writer

1. Feature
 2. Preparation for Use, General Notes and Caution
 3. Parts and its Each Function
 4. Display and Buzzer Sounds (Please read this Chapter)
 - 4.1 Display Parts and its Function
 - 4.2 Preparation for Use
 5. Operation
 - 5.1 Selecting the Target Device and Object File Loading / Saving
 - 5.2 Connecting to the Target System
 - 5.3 Setting the Operating Range (Address Set Function)
 - 5.4 Executing the Device Function (Programming to ROM)
 - 5.5 Checking and Modifying the Data
 - 5.6 Editing the Data
 - 5.7 Serial Interface Operation
 - 5.8 Remote Operation
 - 5.9 Loading and Saving Files, and Generating the Edited Data Files
 - 5.10 Other Functions
 6. Remote Control
 7. Specification
 - 7.1 Operating Condition
 - 7.2 Host Interface
 8. Commands
 - 8.1 Function Commands
 - 8.2 Device Function Commands
 9. Error Codes
- Appendix 1 Standard Probe A (AZ210)
 Standard Probe B (AZ211) and D (AZ213)
 Standard Probe C (AZ212)

Instruction Manual

No. 1079CB-09

Revision History

Revision	Publication Date	Details of Change
Version 1	December 20, 1996	Initial Publication
Version 2	February 14, 1997	
Version 3	April 11, 1997	
Version 4	April 25, 1997	
Version 5	July 10, 1997	
Version 6	February 22, 1998	Standard Cable B and C
Version 7	March 19, 1998	Internet Prep
Version 8	April 4, 1998	5-10-2- Recommended Initial Values of tB to tE
Version 9	September 1, 1998	All Pages

Notices

- (1) This manual may not be reproduced, neither in whole or in part, without permission.
- (2) The contents of this manual is subjected to change without notice.
- (3) Please contact YDC or your local distributors regarding any problems or suggestions.
- (4) Regardless of (3), Yokogawa Digital Computer Corporation (YDC) accepts no liability for damages arose from the use of this product.

(C) 1998 Yokogawa Digital Computer Corporation. All rights reserved. Printed in Japan.

To Ensure Safety Use of Flash Writer

In order to ensure the proper and safety use of Flash Writer, please be sure to follow the safety caution mentioned below as operating Flash Writer. Yokogawa Digital Computer Corporation has no responsibility nor guarantee for any injuries which occur as a result of the violation of these safety caution and warnings.

- Following safety-related symbols are used on Flash Writer and its instruction manual for a safety use.



It indicates not only that there is a danger to humans as well as to the equipment, but also that it is necessary to refer to the instruction manual.



It indicates a safety ground terminal. As this terminal is on the main unit, please be sure to connect this terminal to the ground before operating.

Warning!: In order to avoid the risk of death or serious injury which may occur as a result of an incorrect use.

Caution!: In order to avoid the risk of minor injury or material damage which may occur as a result of an incorrect use.

To avoid the risk of death or serious injury to users, such as electrocution or any other accidents, as well as the risk of damage to Flash Writer, please follow the warnings mentioned below.

Warning!

- **Use in Chemical Gases**
Do not use Flash Writer in an environment where are combustibile or explosive gases or steam. Using Flash Writer in such environment is extremely dangerous.
- **Power Supply**
As Flash Writer is designed to prevent the electrocution or any other accidents, be sure to use the power supply pack (AC adapter) specified by Yokogawa Digital Computer Corporation ONLY. The power supply pack is designated as an option with /ACP.

Confirm that the supply-side voltage matches to the rated power supply voltage for a power supply pack. Also ensure that the power supply switch (on the back panel) of Flash Writer is switched "OFF" before connecting to the power cord.
- **Changing Fuses**
Flash Writer is provided with internal fuses at its DC power supply input. If a fuse melts, contact Yokogawa Digital Computer Corporation, or its maintenance department to request a replacement of the fuse. Since it is seriously dangerous for users to replace any fuses or a shorted fuse, we request that the users should no attempt to replace a fuse by themselves.
- **Removing the Case**
Only qualified service engineers should remove the case of Flash Writer because of the high voltage.

Making the Most of Flash Writer

The Flash Writer is an electronic device which consists of high-precision electronic components. Please be sure to understand and follow the caution listed below in order to avoid any accidents and as well as to make the most of your Flash Writer.

1. Switch ON / Switch OFF Sequence

Warning!

- Refer to the Switch ON / Switch OFF sequence below regarding Switch ON and OFF of the host computer, Flash Writer, and the target system.
- The Switch ON / Switch OFF sequence should be followed in order to avoid major damages to the target system and Flash Writer itself. (especially between Flash Writer and the target system).

<Power Up Sequence>

- (1) Host computer
- (2) Flash Writer
- (3) Target system

<Power Down Sequence>

- (1) Target system
- (2) Flash Writer
- (3) Host computer

2. Connecting the Probe and Connector

Warning!

- Switch OFF the power supply of Flash Writer and the target system before plugging in or unplugging any probes or cables.
- All probes and cables are designed to prevent an incorrect connection. Never force them to plug in nor unplug. Confirm the position and direction.

3. Disassembling Flash Writer

Warning!

- Since Flash Writer contains printed circuit boards with minute patterns, never remove screws or disassemble Flash Writer.

Flash Writer

To make the most of Flash Writer, please read and understand AF200 Flash Writer Instruction Manual before use. After reading the instruction manual, please keep it for the further reference whenever required.

Please ensure that Flash Writer should be used only by persons who have read and understood the instruction manual. We strongly recommend that the first-time users receive an proper instruction from those who have a good knowledge of Flash Writer.

What is Flash Writer?

The Flash Writer is AF200, Flash Writer main unit, control modules, and other related products manufactured by Yokogawa Digital Computer Corporation. The target system and the host computer are strictly excluded.

Flash Writer is an electronic device which consists of the high-precision electronic components. In order to make the most of Flash Writer and also to prevent any accidents, please follow the caution listed below.

A certain repair fee is required regarding the equipment damages resulted from an incorrect use or connection, etc.. Please aware that it may require a few months for repairs.

Regarding software products and manuals, YDC guarantees only if there are any damages of media provided by Yokogawa Digital Corporation, manual defects or trouble executing the program installation.

If proved that there are bugs or that there are problems apart from those listed above, the action will be taken based on the maintenance agreement.

Caution!

- Be sure to Switch OFF the power supply of Flash Writer and the target system before plugging in or unplugging any cables between Flash Writer and the target system. Be aware that plugging in or unplugging any cables while the power supply is ON, may result in an explosion or ignition of Flash Writer or the target system.
- Before Switching ON the power supply, be sure to confirm whether the direction of Pin 1 in the probe tip matches to Pin 1 Socket in the target system. An incorrect connection may result in an explosion or ignition of Flash Writer or the target system.

Warning!

- As particular parts of electronic circuits in the probe tip are exposed, Flash Writer should be used only in environments where are protected from a static electricity. Using Flash Writer in such environment as without static electric protection, may result in destroying Flash Writer or the target system.
- The Switch ON / OFF sequence should be followed. Flash Writer should be switched ON prior to the target system and remained ON while Switch ON / OFF of the target system power supply. An incorrect Switch ON / OFF sequence may result in a serious damage to Flash Writer or the target system circuits.

1. Feature

AF200 is a soldered on (the target system) flash micom programmer which programs flash built in micoms with various programming methods. With control modules (PC Cards) sold separately, AF200 programs the internal flash memory matched to the each programming specification.

Feature

- Programs the internal flash memory with a control module matched to each micom.
- Is connected to the user system with a target probe cable. Overwrites flash memory to the target micom, as soldered on.
- High speed flash memory programming.
- High speed search for the modified data.
- The modified data is saved in the PC card.
- The programming data is saved in DOS Area and is easily transferred from the host computer.
- Easy operation with Ten Key.
- Optional remote control is available.

2. Preparation for Use, General Notes and Caution

(1) Power Supply

Use only power supply units (optional ACP for Japan, or AC2P for outside Japan) provided by Yokogawa Digital Computer Corporation. Before connecting the DC jack, unplug the AC plug and confirm whether the AF200 power supply switch is OFF.

(2) The Operating Environment

Do NOT use AF200 in following environment, such as dusty, direct sun-lightened, or corrosive gassy.

(3) Temperature and Humidity

Use AF200 only in following environment, between 5 and 40 °C and 20 and 80% rH.

(4) Power Line Noise

If an excessive noise on the AC power line, use such as noise filters to clear noise.

(5) Initialisation

Do NOT initialise (reformat) control modules (PC cards).

The control module contains DOS Area which consists of the user program, as well as the flash writer control program (definition part).

Initialising PC cards could lead to a serious damage to the control program (definition part). NEVER format PC cards.

Do NOT insert or remove control modules during the operation such as programming.

(6) Control Module Insertion

Do NOT insert or remove control modules during the device function or function execution. The media can not be inserted or removed during the access to PC cards, as floppy disks .

(7) System Switch ON / OFF Sequence

Follow the system Switch ON / OFF sequences for AF200 and the target system. Switch ON AF200 first, then the target system. And Switch OFF the target system first, then AF200.

(8) Control Modules

AF200 operates only as a control module (sold separately) is connected to a proper PC card connector. If the PC card is removed, AF200 does not operate.

Regarding the definition part damage resulted from an incorrect use as listed in Chapter 5 and 6, YDC offers an definition part programming with certain engineering fee. Contact YDC or your local distributors for further details.

YDC offers AF200 and other related products' news and manuals on our home page.
YDC's Home Page: <http://www.ydc.co.jp/micom/index.htm>

3. Parts and its Each Function

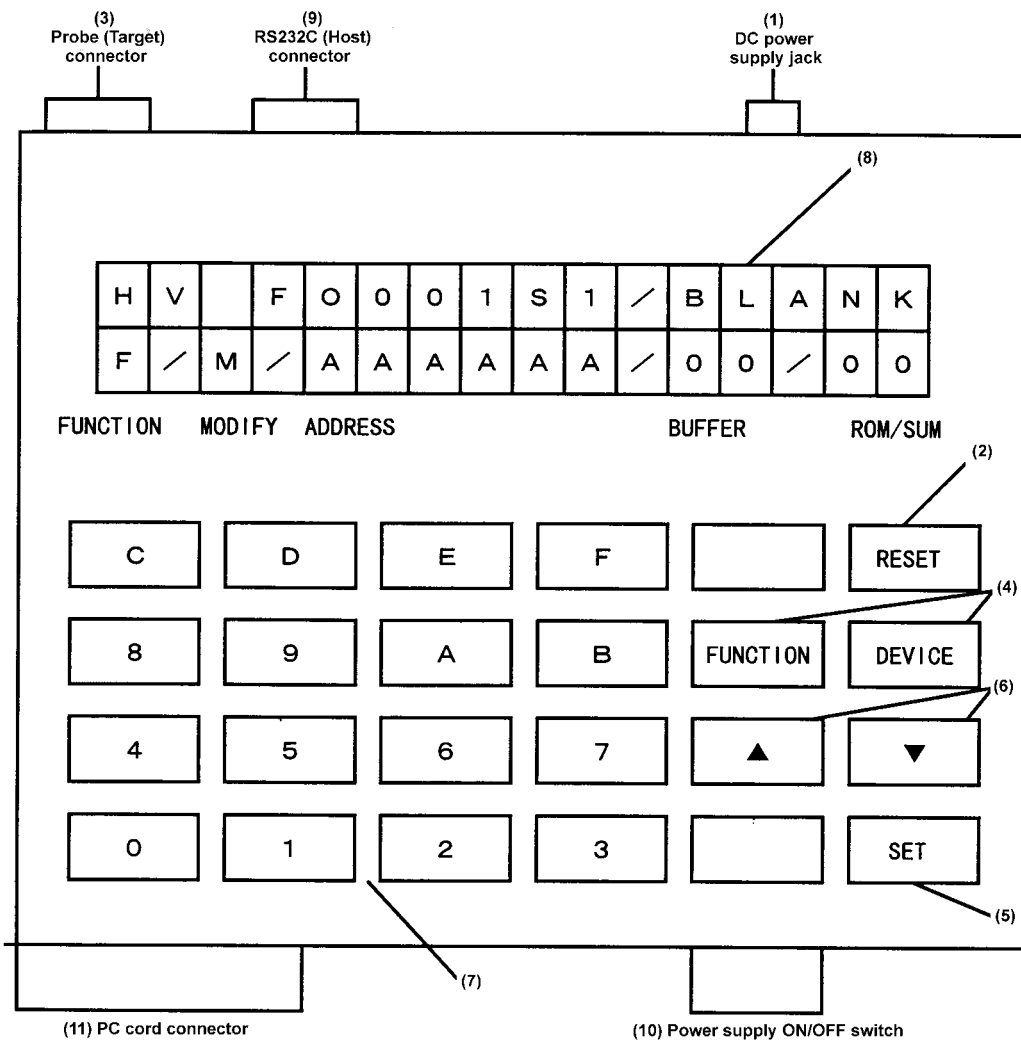

- (1) **DC Jack**
A jack for connecting the AF200 power pack (centre +).
- (2) **RESET Key**
Use RESET key to cancel an operation or an error display as well as the remote operation.

- (3) **Probe Connector**
A connector to connect a probe in order to connect AF200 to the target system.
- (4) **Command Keys**
Use command keys, such as "FUNCTION" key and "DEVICE" key for each operation.
- (5) **SET Key**
Use SET Key to set and execute various modes and commands selected by FUNCTION key and DEVICE key. It is also used to modify the data in Buffer RAM.
- (6) **Increment and Decrement Keys**
Use increment and decrement keys to increase or decrease address values as well as to display the Buffer RAM and ROM data in the corresponding addresses simultaneously. These are also used to select parameters in "FUNCTION" operation.
- (7) **Data Keys**
There are 16 Data Keys, from "0" to "F" and are hexadecimal numbers. Keys, 8 to A and C to F, are also used as subcommand keys in the device function.
- (8) **Display**
- (9) **RS232C Connector**
A connector for the serial communication (RS232C) in order to connect AF200 to the host computer.
- (10) **Power Supply ON/OFF Switch**
- (11) **PC Card Connector**
The control data for AF200 is stored in each of the control modules matched to the each target micom.
AF200 does not operate without a proper control module.

4. **Display and Buzzer Sounds (Please read this Chapter.)**

4.1 **Display Parts and its Function**

(1)		(2)						(3)							
H	V		F	0	0	0	1	S	1	/	B	L	A	N	K
F	/	M	/	A	A	A	A	A	A	/	0	0	/	0	0
(4)		(5)		(6)						(7)			(8)		
FUNCTION		MODIFY		ADDRESS						BUFFER			ROM/SUM		

- (1) **Vpp Power Display**
Indicates the device function execution.
A high voltage can be switched off by RESET key.
- (2) **Control Module Name Display**
Indicates the control module model name which is actually located in the PC card connector.
- (3) **Device Function Display**
Indicates the device function which is being executed.
- (4) **Function Display**
Indicates the function which is being executed.
- (5) **Modify Bit Display**
Indicates the modify bit. As the Buffer RAM data is modified by the key entry or Buffer transfer, "M" is displayed to indicate that the data is modified.
- (6) **Address Display**
Indicates that the flash memory address display and data keys.
Use lower 6 figures for the flash memory address.
- (7) **Buffer**
Indicates the Buffer RAM data, the error codes and etc.
- (8) **ROM Data/Sum Check Display**
Indicates the ROM data which is set to the ROM socket, and the sum value of the Buffer RAM data.

4.2 Preparation for Use

Refer to Chapter 5 regarding each function setting as well as the preparation for use. As using AF200 with AZ290: Remote Controller, refer to 4.2.1. If as standalone, refer to 4.2.2, 4.2.3 and 4.2.4 for initial settings.

Please confirm whether the control module **does** match to the target micom before following settings.

- a. Does the target micom have the same programming method as the model micom's ?
- b. Do the programming voltage Vpp and the writing control algorithm match to the model micom's?
- c. Is WCP (Writing Control Program) already prepared for those target micoms which require WCP to be downloaded to the micom in advance?

4.2.1 Setting the Host Interface (As Using with a remote controller)

Set the serial communication interface as using with AZ290:Remote Controller.

→ Setting the transfer speed and I/O Parity: Refer to Chapter 5.7.5.

Settings in Chapter 4.2.2, 4.2.3 and 4.2.4 can be executed on the remote controller window.

Refer to AZ290:Remote Controller Instruction Manual regarding the initial settings from the remote controller.

Refer to AZ290:Remote Controller Instruction Manual regarding those settings in Chapter 4.2.2, 4.2.3 and 4.2.4.

4.2.2 Initial Settings for the Target Micom

- (1) Setting the Communication Interface (Function D1)
Select a communication interface on the target micom to connect to the flash writer.
Refer to Chapter 5.10.2 (1).

As using UART, select the UART communication speed (Function D2) and the communication channel (Function D7).

→ Selecting the UART communication speed: Refer to Chapter 5.10.2 (2).

→ Selecting the UART communication channel number: Refer to Chapter 5.10.2 (7).

As using CSI, select the CSI communication speed (Function D9) and the communication channel (Function D7).

→ Selecting the CSI communication speed: Refer to Chapter 5.10.2 (9).

→ Selecting the CSI communication channel number: Refer to Chapter 5.10.2 (7).

- (2) Setting the TVcc Threshold (Function D3)
Set the operating voltage for the target system. Set 4.5 volts for the 5 volt operating system. Set 2.7 volts for the 3 volt operating system.
→ Refer to Chapter 5.10.2 (3)
- (3) Setting the Target MCU Mode Selection (Function D4)
If there are multiple operating modes during operating, set the same operating mode.
Refer to each manual of control modules and micoms regarding the micoms' own specific operating mode.
→ Refer to Chapter 5.10.2 (4).

- (4) **Setting the Watchdog Timer Interval**
Set the Watchdog Timer Interval only if the target system circuits have a watchdog timer circuit and the pulse-output to this watchdog circuit is required during programming and application read.
→ Refer to Chapter 5.10.2 (5).
- (5) **Displaying the Flash Memory Area**
Confirm the first and last addresses for the internal flash memory by using Function D6. The first and last addresses for the internal flash memory can be set by using the parameter setting tool: AZ290 (sold separately).
→ Refer to Chapter 5.10.2 (6)
- (6) **Setting and Displaying the Display Model Name**
Set the specific display model name by users, to the customised control module. For example, input a specific micom model name for the control module management.
→ Refer to Chapter 5.10.3 (8)
- (7) **Setting the Application Read Parameters**
Set functions DA to DF if using the application read mode.
- (8) **Executing the Buffer Clear Function**
Execute the buffer clear function to initialise contents of the buffer memory.
→ Refer to Chapter 5.6.2 (2).

4.2.3 Programming First Address and Last Address

Set addresses to program by **[FUNCTION 0]**.

→ Refer to Chapter 5.3.1.

4.2.4 File Loading and Saving

Set the target buffer memory area during the file loading and file saving by **[FUNCTION F 5]**.

Normally the target area is set by **[FUNCTION D 6]** and same as the internal area of the micom.

Notes;

The target area of each function are defined by following 3 functions. Understand all of three and set properly.

Function Code	Definition	Reference
0	Define the Target Area during the device function execution such as programming and readout. Set as follows; F: First Address = Lowest Value of Internal Flash Memory L: Last Address = Highest Value of Internal Flash Memory rF: ROM First Address = F: First Address	The Target Area of the device function such as partial programming can be defined by modifying F,L and rF.
D 6	Internal Flash Memory of the Target Micom	Use AZ290: Remote Controller (sold separately) for the parameter modification.
*1 F 5	Define the Target Memory Area while the command execution such as file save, object downloading and uploading. Set as follows; (Example as 512K bytes Internal Flash Memory) F: First Address = Lowest Value of Internal Flash memory L: Last Address = (F+512K bytes) Address Notes; If a micom defines the Flash Memory Area to the lower address, L: Last Address = Highest Value of Internal Flash Memory F: First Address = (L-512K bytes) Address	

*1 As loading and saving files if the address defined by **[FUNCTION F 5]** is not covering all area, **ONLY** the data defined by **[FUNCTION F 5]** is loaded or saved. (Same for the modified data.)

4.2.5 Programming

As the preparation for use is completed, Switch OFF AF200 main unit and connect AF200 to the target system with a probe in a control module pack.

→ Switch OFF the target system as well during the connecting procedure.

As the probe is properly connected, Switch ON AF200 main unit. After the control module model name is displayed, Switch ON the target system.

All the procedures below are as using AF200 as standalone. Confirm all operation as standalone first even if using AZ290: Remote Controller,

- (1) Loading the specific program data into the buffer memory
Refer to Chapter 5.9.1 regarding the file loading.
As AF200 programs with a generic flash microm, AF200 outputs a high voltage (approximately 13 V) to the target system through the probe in order for programming. Please follow the procedures shown below to avoid the destruction of the target system by an incorrect operation.
 - a. YDC recommends that ONLY flash microm files matched to the control module model should be generated to the control module.
Generating object files of differentiate microm may result in providing an incorrect programming voltage as well as an incorrect operation.
- (2) Programming the loaded data to the flash microm.
→ Refer to Chapter 5.4.1 (4) regarding data programming using device function E,P and R.
- (3) Checking the programmed contents
Check the contents using the editing function.
→ Refer to Chapter 5.5 regarding the data confirmation and modification.
- (4) "HV" on the display (Refer to Chapter 4.1) indicates that Vpp (the programming voltage) is being outputted from the writer through the probe.
Switch OFF the target system and plug in or unplug the probe after clicking RESET Key and "HV" being no longer on the display is confirmed.
"HV" is displayed while device function execution and mode editing operation.

5. Operation

5.1 Selecting the Target Device and Object File Loading / Saving

<Selecting the Target Device>

AF200 operates with specific control modules (PC cards) prepared for each target micom. (AF200 does not operate without control modules.)

Connecting an inappropriate flash micom (which does not match to the specific control module) may result in destroying the target system.

Control modules contain the definition part for each micom. (approximately 300 K bytes). Other areas in the control module (PC card) are the data areas with the DOS file format. Object files created on the host computer are stored in DOS Area.

Caution: The definition part can not be accessed on a PC as is stored outside DOS Area,

File Loading

A object file in the control module can be selected by clicking

.

Select a proper file by clicking and keys.

As a file is selected, click to load into Buffer RAM.

Notes;

Define files to be located in the control module, by following procedures.

1. File Name: 8 Letters begin with alphabets or numbers
2. Extension
 - Intel HEX Format File → XXX.HEX
 - Motorola S Format File → XXX.S
 - Booted Program File → XXX.BTP
 - Security Key File → XXX.KEY

5.2 Connecting to the Target System

Signal names on the AF200 probe connector and interface parameters are shown on the next page.

Connect an input signal line (on the target system) to the target system (TVcc) with approximately 10Ω resistor in case of AF200 not being connected.

Pull up /TICS signal by 10K Ω.

Refer to each control module manual regarding the connection to the target system which micoms are mounted.

(Depending on control modules, there are particular signal lines that are not subject to control by AF200.)

Signal Name (Bin No.)	Definition	Output Type	Notes
TVcc (2)	User Vcc Monitor Input Signal *1 Within the Flash Writer, TVcc is used for the power supply of 74VHC367 and 74VHC125 other than TVcc monitor itself.	Type 1	
/TRES (5)	Reset Control Output Signal to the target System (Low: RESET) /TRES is a CR open output equivalent to SN74LS07.	Type 2	
TRES (4)	Reset Control Output Signal to the target System (H: RESET) TRES is a 0 to 5 V totem pole output.	Type 3	
TCK (6)	Serial Sync Clock Output	Type 3	
TAUX2 (TR/W) (9) *2	Data Output Control Signal for IN/OUT shared terminal-type H: Input L: output (writer to target)	Type 3	*2 *3
/TICS (10)	Control Signal to indicate multiplexing the communication channel to the programmer The circuit in the target micom is connected to the communication channel by /TICS.	Type 3	
TAUX5 (/TOE) (11)	Auxiliary Control Signal	Type 3	*2 *3
TAUX (23)	Auxiliary Control Signal	Type 4	*2 *3
TTXD (13)	Serial Data Output Signal from the flash writer TTXD is used for a single line serial (bi-directional) device.	Type 4	
TVpp1 (16)	High Voltage Power Supply Output Signal for programming TVpp1 outputs a specific programming power supply for each micom. Put 0.1 to 100uF capacitor between TVpp1 and GND, close to the target micom.	Type 5	*4
TAUX3 (TVpp1c) (19) *2	TVpp1 Control Output (0 to 5 V) TAUX3 is a control output for switching the target system-side Vpp1 ON and OFF. (5 V: TVpp1 ON control).	Type 4	*2 *3
TVpp2 (17)	High Voltage Output for the programming mode Put a capacitor (0.1 to 100uF) between TVpp2 and GND, close to the target micom.	Type 5	*4
TAUX4 (TVpp2c) (20) *2	Control TVpp2 Signal Used as TVpp2 is generated on the target board. (5V: TVpp2 ON control)	Type 4	*2 *3
TMODE (12)	Auxiliary Control Signal (I/O)	Type 3	*3
TBUSY (24)	Auxiliary Input Signal	Type 6	
TRXD (27)	Serial Data Input Signal	Type 6	
Vcc (3)	Outputs AF200 Vcc Output (+5V) through a fuse resistor.	Type 7	
WDT (18)	Clock Signal for watchdog timer circuit Outputs only as /TICS is asserted.	Type 2	
TI0 (25)	Auxiliary Input Signal	Type 6	*3
TI1 (26)	Auxiliary Input Signal.	Type 6	*3
1,7, 8, 14, 15 21, 22, 28	GND		

*1 Input and Output are defined as “to” and “from” AF200.

*2 TAUX2 to TAUX5 are used as the signals as defined above unless no other definitions are mentioned in each control module.

*3 Signals with *3 are defined by each control module.
Refer to Control Module Manuals for further details.

*4 500 mA is included

The Writer-side Connector (The Connector which is Mounted in Writer)
DX10-28S

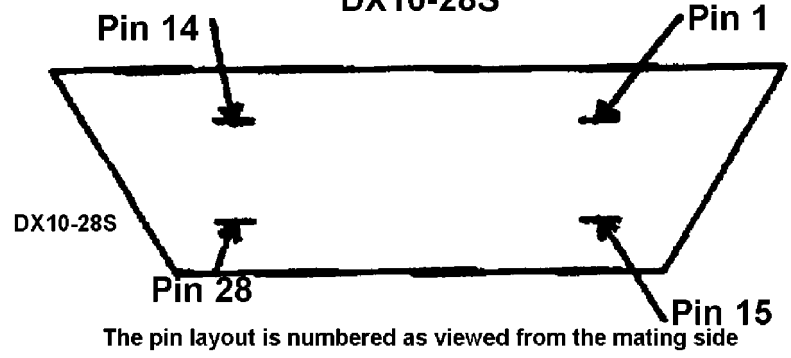

Types of Interfaces

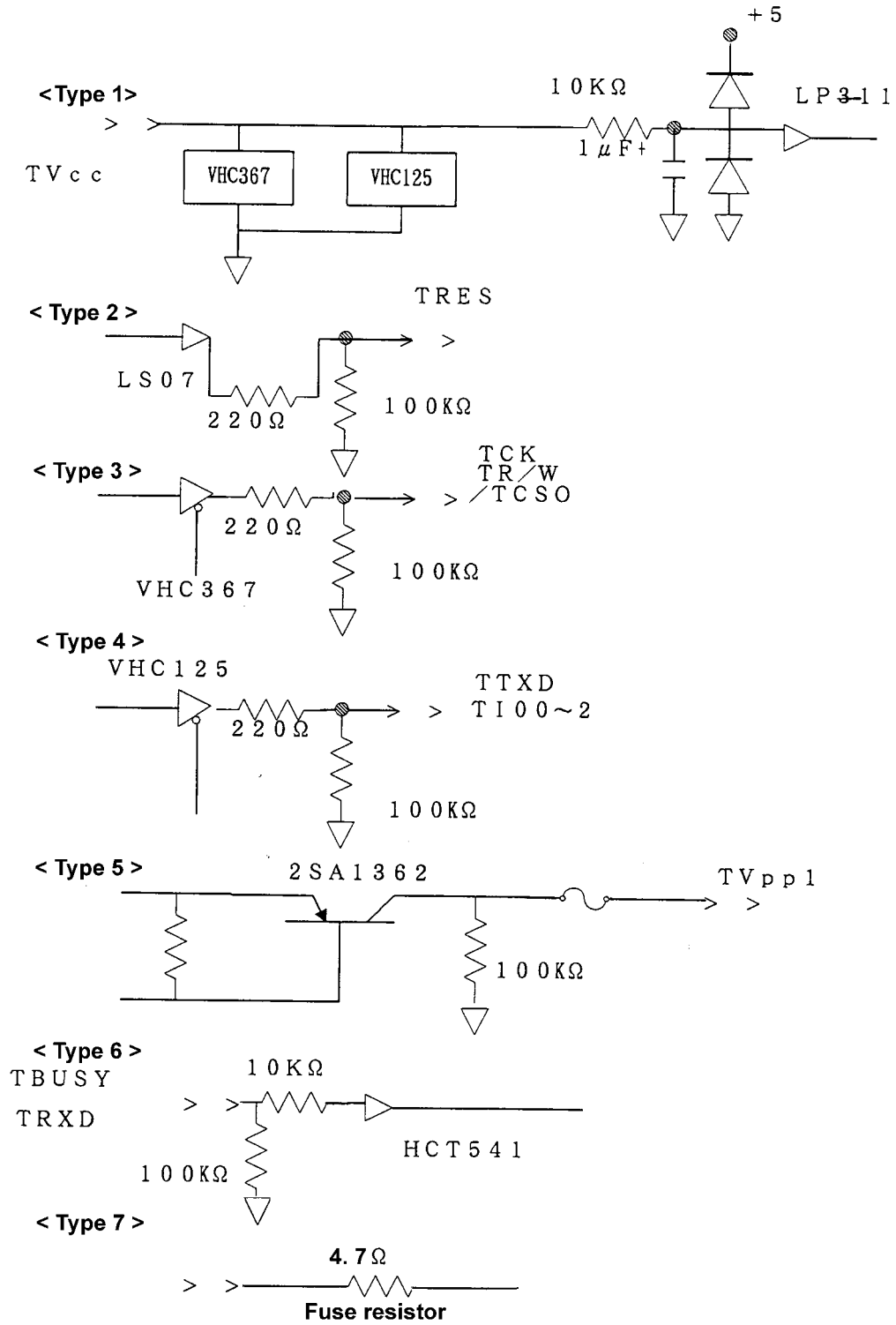

Note; The fuse resistor is 4.7 for AF200, 1.0 for AF200A.

5.3 Setting the Operating Range (The Address Set Function)

For device functions (erase, blank check, program, read check, etc.) the operating range can be set for the device (ROM) and Buffer RAM in advance. Following items can be set in AF200 by using the address set function.

Click

Note; Depending on the basic function of the target micom's programming mode, Check and Blank Check Function may use the entire internal flash memory.

- (1) First Address (Set by the lower six digits of the flash memory address)
Programming and reading is executed on the content of the specified current file address.
- (2) Last Address (Set by the lower six digits of the flash memory address)
Reading / Programming stop at the address specified as the Last Address. Be sure to specify a larger value for the last address than for the first address.
- (3) Flash ROM First Address
This is the address for the flash-ROM side. Reading / Programming starts with the address specified here. Be sure that this address matches to the first address specified in (1), above.

5.3.1 Example of Key Operation

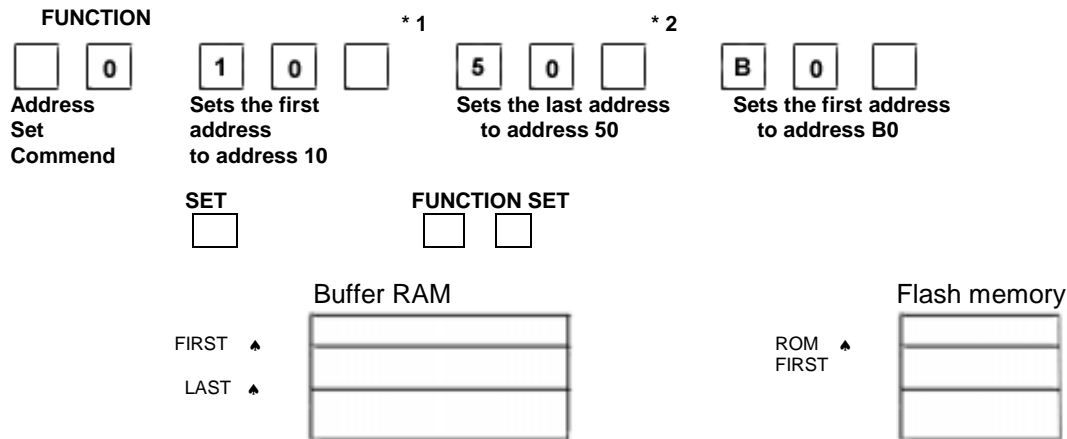

Note; Be sure that the "F" (first) address matches to the "rF" (ROM first) address.

*1 As clicking command keys, **FUNCTION** and **0**, a symbol indicating the identification of each parameter, is displayed on the "BUFFER" display, Its content is displayed on the "ADDRESS" display.

BUFFER

F First: Indicates the first address of Buffer RAM. Shown with the lower six digits of address in the free are in the target micom.

L Last: Indicates the last address of Buffer RAM. Shown with the lower six digits of address in the free area of the target micom.

r **F** ROM First: Indicates the ROM first address of Buffer RAM. Shown with the lower six digits of the address in the free are of the target micom.

*2 Inputted parameters take the place of the contents of the "ADDRESS" display. As and keys are clicked, previous / following parameters are displayed.

Note; For parameters requiring no modification, click skip keys: and to set the previous set value (shown on the display) as it is.

Note; For non-overwritable flash micoms (i.e. those require erase before rewriting), if the F (first), L (last) and rF (ROM first) addresses are not matched to the flash memory block boundary, a beeping alarm sounds and the addresses stored in AF200 automatically are aligned to the block boundary addresses. For overwritable flash micom, the automatic alignment can be executed by users. By default, the automatic alignment function is ON. Be careful as using AF200 in the automatic alignment function OFF mode, please contact YDC or your local distributors if use in this mode..

5.4 Executing the Device Function

There are seven modes for the device function. These execute following operations on the address range specified by the address settings.

Use **DEVICE** key to set these modes.

5.4.1 Device Function Operation

(1) Blank Check (BLANK)

It verifies that the device (ROM) is in a blank state.

- * The device is in a blank state: " **P** **A** **S** **S** "is displayed.
- * The device is not blank: A beeping alarm sounds.
- * In a checking process: "BLANK CHECKING"

(2) Program (PROGRAM)

It programs the contents of the buffer RAM to the target ROM.

Set the mode to "PROGRAM" to execute this operation.

- * The display during programming:
"ERASING" "BLANK CHECKING" "PROGRAMMING"
Depending on the control module which is used (i.e., depending on the type of target micom), all or some of erasing, blank checking, and programming functions are executed continuously. Refer to each control module users' manual for further details.
- * The program completion display: **P** **A** **S** **S** is displayed.
- * The error in programming:
The programming stops at the address where the error is detected, with a beeping alarm. With the "PROGRAM" command, the read verification of the programmed contents is not executed.

(3) Read Check (READ)

It compares the contents programmed to the ROM with that of the buffer RAM to ensure whether they match. Set the mode to "READ" to execute this function.

- * The display as the ROM matches to the buffer RAM: "[P] [A] [S] [S]" displayed.
- * The display as the ROM does not match to the RAM:
The address device data detected as not matched is displayed in the "ROM data," and the buffer RAM data is displayed in the "buffer" area. The read operation is paused with a beeping alarm.
- * The display in checking : "READ CHECKING"
Some flash micoms do not support the read function in the flash memory.

- (4) E/P/R Continuous Operation (EPR)
It sequentially executes Erasing (E), Blank Check (B), Programming (P), and Read Check (R).
- * Display during operation:
The function currently being executed can be verified in the device function display area.
 - * Display in an error:
The display is illuminated with a beeping alarm at the function where detected an error .
- (5) Copy / Read Check (COPY)
The contents of ROM are transferred to Buffer RAM, and then Read Check is executed.
- * Copy completion Display: **P** **A** **S** **S** is displayed.
Some flash micoms do not support the read function for the flash memory area.
- (6) Erase / Blank Check [ERASE]
It erases the contents of the flash memory.
As Erase is completed, Blank Check is executed to ensure whether the content of ROM is being erased.
- * Erase completion Display: **P** **A** **S** **S** is displayed.
 - * The target erase area is an entire flash memory including the first, last, and ROM first addresses set by [FUNCTION] [0].

5.4.2 Key Operation

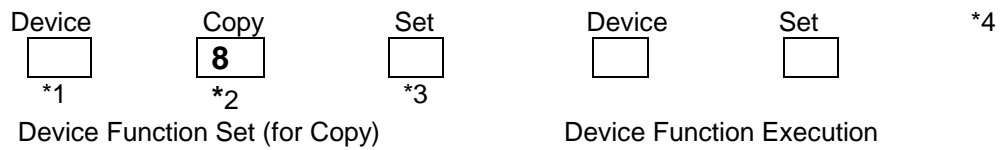

- *1 As clicking device key, **d** is displayed on the **FUNCTION** display, and the device function can be set.
- *2 Click "subcommand" key after "device" key. The contents of address settings is displayed on the "ADDRESS" and "BUFFER" displays.

Device Function Subcommands

Subcommand Key	Device Function	Subcommand Key	Device Function
BLANK 9	Blank Check	COPY 8	Copy and Read Check
PROGRAM D	Program	ERASE C	Erase and Blank Check
READ E	Read Check		
BPR F	EPR continuous operation		

- *3 The function which is set by "SET" key is illuminated on the display. (For example, "COPY.")
- *4 Input either, "DEVICE" or "SET" again to execute.

Note; The device function is set to "COPY" as power-on default.

5.5 Checking and Modifying the Data

The data in Buffer RAM and ROM can be checked or displayed by setting the address, and the contents of Buffer RAM can be modified as well.

Searching a modified data is easily executed because of the modified bit indicating the modified data,

The address is shown by lower six digits of the address in the target micom's free area.

5.5.1 Key Operation

- i) Checking the Data (or) **SET**
RESET *1

 Reset Address Setting Data Display

*1. The data is displayed as follows.

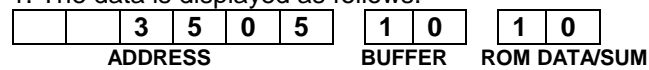

- *2 Check the following data. *2. A previous and following data can be checked by clicking and keys.

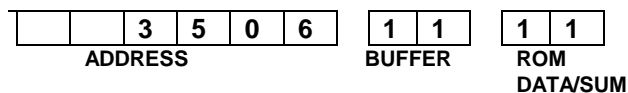

- ii) Modifying the Data **RESET** *1

 Reset Set the data as address 10 Modify the data in address 10

*1. Buffer is "FF".

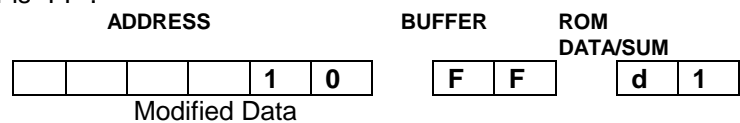

- SET** *2 *2. "FF" is set to the address 10, and the contents of next address are displayed.

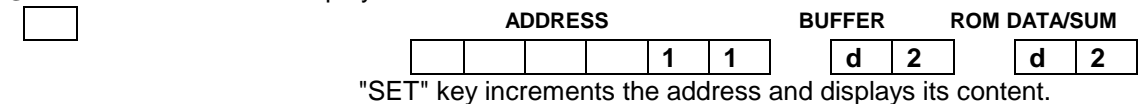

"SET" key increments the address and displays its content.

- SET** Modify the data in address 11.

5.6 Editing the Data

Following editing processes can be executed on all Buffer RAM data.
Be aware that the data editing can not be executed exceeding the contents of Buffer RAM.
All addresses are shown by lower six digits of the target micom's free area.

5.6.1 Data Editing Function

- (1) **Block Store**
Programs a single discretionary number to all addresses in the specified area of Buffer RAM. The Buffer RAM area is specified by the first address (FIRST) and the last address (LAST).
And set a single discretionary number (data), then execute.
- (2) **Buffer Clear**
Programs the erased state data of the micom, to the corresponding are of the Buffer RAM memory. The area equivalent to the flash memory is set by Function D6.
- (3) **Modified Bit Search**
In all Buffer RAM data, the data which is modified through either key or remote operation, it sets its modified bit automatically.
In Modified Bit Search, only these modify bits (i.e., the modified data) are searched, and are displayed in the data display area, with "M" indicating the data modification.

Modify Bits can be cleared or set as executing following operations:

Clear / Set	Command	Range
Clear	DEVICE COPY	From First address to Last Address
	Serial IN (FUNCTION 41)	Data Area defined in Chapter 5.9.4
	Buffer Clear	Entire Buffer Area
Set	RAM MODIFY	Modified Bits
	Block Store	From First Address to Last Address

5.6.2 Key Operation

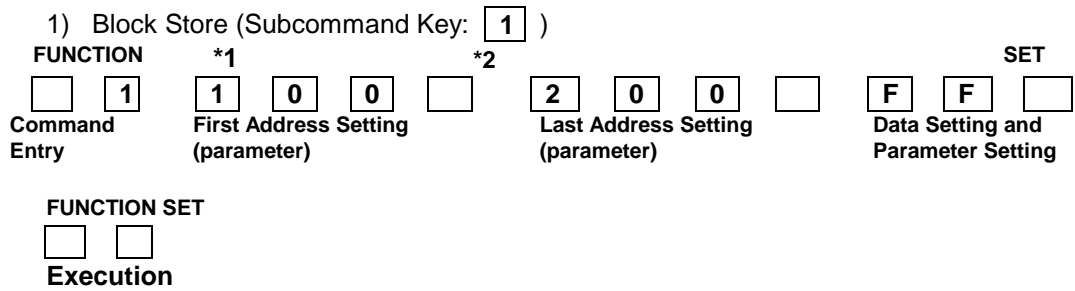

*1 As a command, is entered, the codes indicating the identities of various parameters are displayed in the Buffer area of the display, and the contents of parameters are displayed in the "ADDRESS" display.

- BUFFER Block Store
- First: Indicates the First Address in Buffer RAM.
- Last: Indicates that the Last address in Buffer RAM.
- Data: Indicates that the data to be stored.

*2 The contents displayed on "ADDRESS" take the place of inputted parameters. As clicking and keys, the subsequent parameter are displayed.

(2) Buffer Clear (Subcommand Key:)

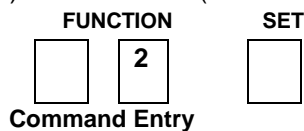

FUNCTION SET

Execution

The target micom's initial value of the flash memory (erased state) is programmed to the entire Buffer area by execution key.

(3) Modify Bit Search (Subcommand Key)

FUNCTION	SET	FUNCTION SET
<input type="text" value=""/>	<input type="text" value="3"/>	<input type="text" value=""/>

Command Entry and Function Setting

*2	*1	Execution
<input type="text" value="M"/>	<input type="text" value=""/>	<input type="text" value="2"/> <input type="text" value="A"/> <input type="text" value="A"/>
		<input type="text" value="8"/> <input type="text" value="8"/>

*1 As Modify Bit Search is executed, the address and the Buffer RAM data are displayed in the display area.

*2 After the execution, use keys to display the previous and subsequent modify bit data.

5.7 Serial Interface Operation

The data is input to or output from Buffer RAM through a serial interface.
 The serial output of the modify bits in the modified data is also executed.
 The operating range is applied to the area defined by the address set function.

5.7.1 Serial In Operation

The serial operation is executed by .

As the serial operation starts, the system waits for the data to be input.
 As the data is inputted including the last address defined by the address setting, the system enters a receive state, and stops the output of the read state signal.

If the data input stops before the last address is entered, the system waits until the data is entered.

Resetting this state is executed either by putting input lines into a break state, or by clicking key.

5.7.2 Serial Out Operation

The serial out operation is executed by **FUNCTION** **4** **2** **SET** **FUNCTION** **SET** .

As the serial out operation is executed, the data output starts one second after.

(* This allows time for the remote command to echo back so that when the serial out operation is started by a remote system, the system can discriminate between the command that was echoed back and the serial data.)

As the serial out operation is started through a remote system, a correct echo back data from the remote command can be transmitted two seconds after the transmission is completed.

Note;

1. As a remote command is entered while the serial out operation is being executed, the echo back of data in the serial out data is transmitted.

5.7.3 Serial I/O Key Operation

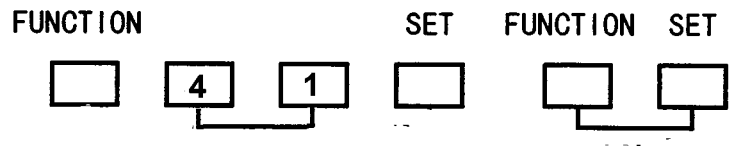

Command (serial in) *1 Settings

*1 command

4	1
4	2

Serial In
Serial Out

Before executing the data I/O, the format, transmission speed, and serial I/O parity can be specified.

5.7.4 I/O Interface Format

The I/O interface format is set by clicking **FUNCTION** **5** .

There are 3 format types, which are specified with a two digit code.

The record length is a parameter which determines the length of a single record.

The record length can be set between "1" and "FF" (in hexadecimal numbers).

Example of Key Operation

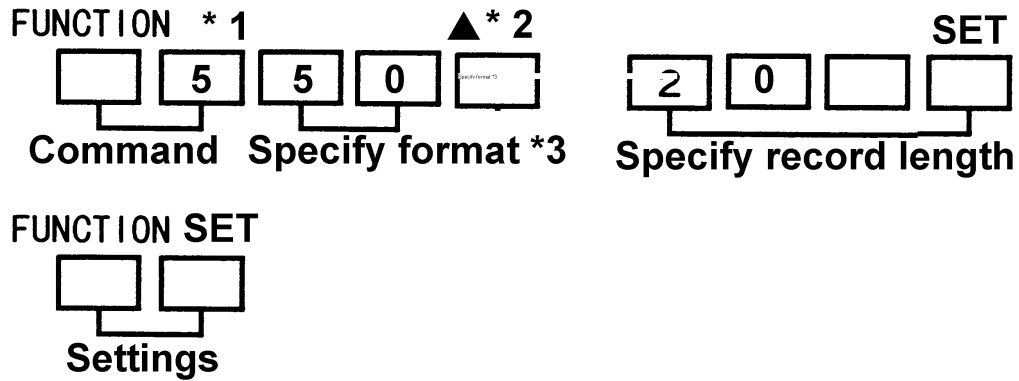

*1 As the command, **FUNCTION** **5** is entered, codes indicating the identification of various parameters are displayed in the "BUFFER" area, and their contents are displayed in the "ADDRESS" area.

BUFFER

—	F	FORMAT:	Indicates the format.
—	L	LENGTH:	Indicates the record length.

*2 The inputted parameter replaces the contents of the "ADDRESS" part of the display. Use and keys to display other parameters.

Format	Code
Intellec	[5] [0]
Motorola	[6] [0]

5.7.5 Specifying the Transmission Speed and Serial I/O Parity

Use **FUNCTION** **7** command key to specify the transmission speed and serial I/O parity.

The transmission speed (BAUD rate) can be selected from following 7 types and be specified with a single-digit code.

BAUD RATE	2400	4800	9600	19200	38400	57600	76800
Code	[1]	[2]	[3]	[4]	[5]	[6]	[7]

As specifying the parity, stop bits, line check, and unit codes are specified as well as parity (no parity, odd parity, or even parity) using a two-digit code.

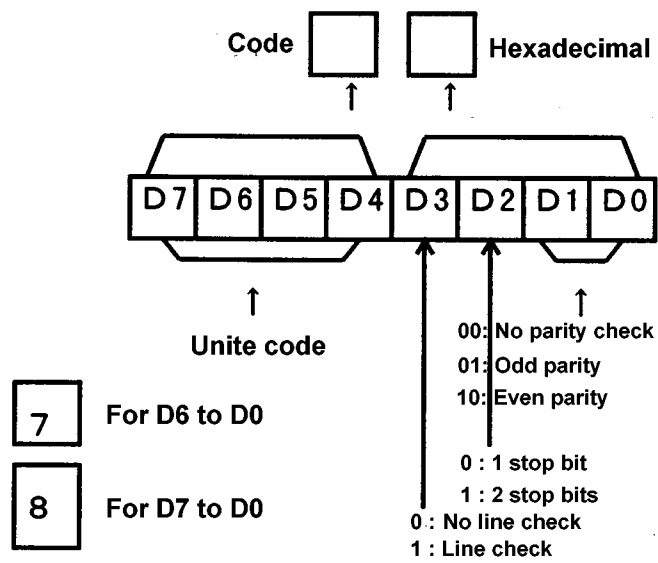

5.7.6 Transmission Speed and Parity Key Operation

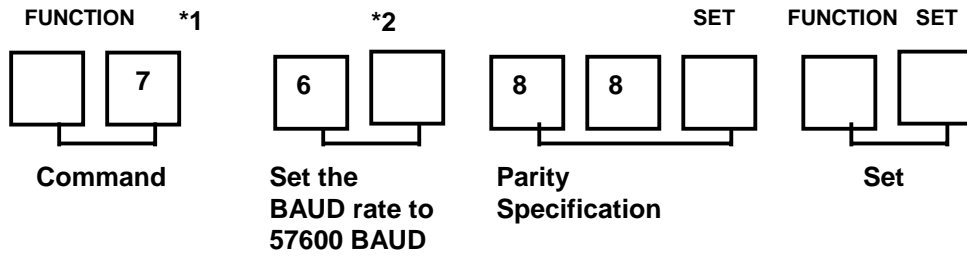

* As the FUNCTION 7 command is entered, codes indicating the identification of various parameters are displayed on the "BUFFER" part of the display, and their contents are displayed on the "ADDRESS" part.

BUFFER

—	b	BAUD:	Indicates the transmission speed.
—	p	PARITY:	Indicates the parity.

*2 The inputted parameter replaces the contents of the "ADDRESS" part of the display. Use and keys to display other parameters.

5.8 Remote Operation

All key operations can be remote controlled through ASCII commands as the serial input in a remote state.

For key operations, use commands shown below corresponding with the keyboard commands.

Keyboard	Code (ASCII)	Keyboard	Code (ASCII)
0 - F	0 - F		
COPY	8	FUNCTION	U
ERASE	C	ROM TYPE	R
PTR	A	DEVICE	V
BLANK	9		SP
PROGRAM	D		/
READ	E	RESET	ESC
BPR	F	SET	CR

Remote Key Equivalents

5.8.1 Operation Notes and Caution

- 1) All inputted codes are echoed back. If CR (carriage return), CR / LF (carriage return / line feed) is echoed back.
- 2) With a reset, the system returns to an initialised state automatically. "CR", "LF" and "*" are transmitted.
- 3) For invalid input keys, a "<" sign is transmitted after a key code is echoed back.
- 4) The flash writer display data is transmitted in the following format:

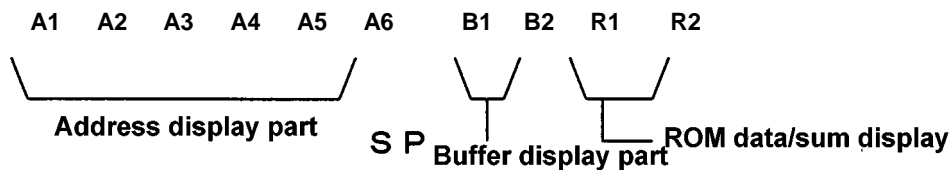

- 5) As a circuit is broken while remote commands are being received and a data break is discovered, the system automatically returns to the local mode after executing a serial I/O initialisation.
- 6) As "RESET" key is clicked or the remote code (ESC) is entered, or the command for releasing the remote mode (U92CR) is received from the remote, the system switches from the remote mode to the local mode.
- 7) If reset while the transmitting the data from the serial input through a remote operation, the serial input of AF200 switches to the break mode.
- 8) If there is an error in the device function or in the I/O input execution, use reset key to return to an initialised state.
- 9) As commands are input from the console, at least 30 msec must be provided between commands.

5.8.2 Example of Remote Operation

- (1) Switching from the local mode (keyboard control) to remote mode.

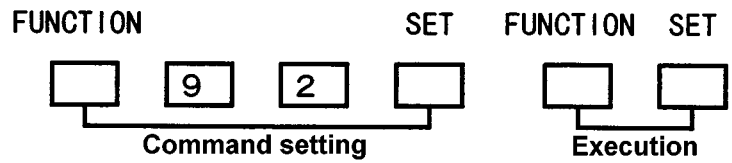

- (2) Switching from the remote mode to local mode. Input from the console.

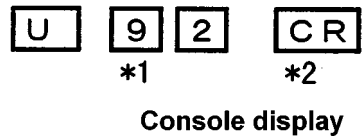

- *1 Commands and the data from the console are echoed back at every single character.
 *2 CR and LF are echoed back in CR.

- (3) Changes in the Buffer RAM data.

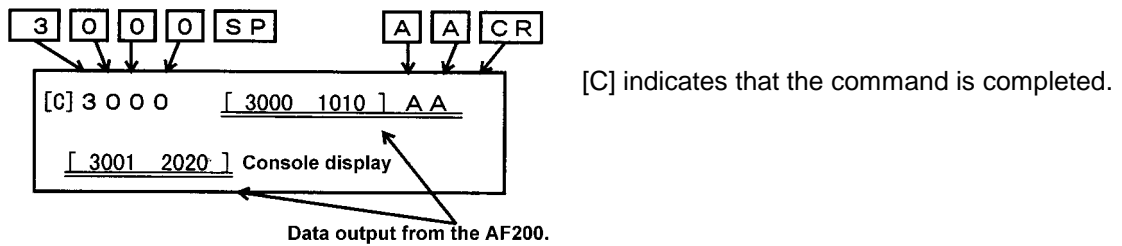

- (4) Executing EPR

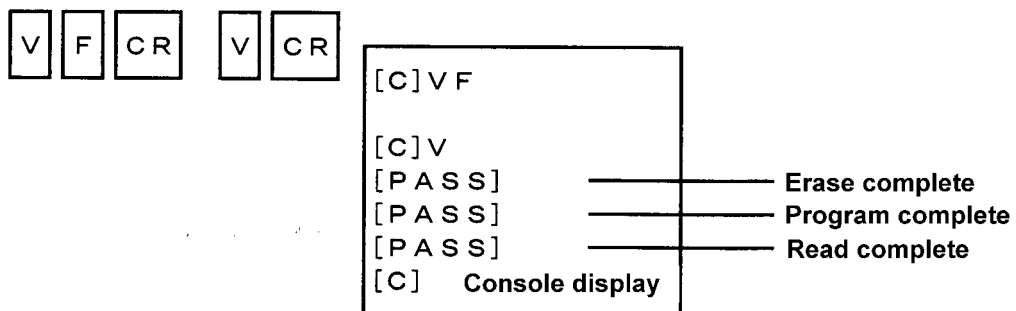

5.9 Loading and Saving Files, and Generating Modified Data Files

Files (hex files, binary file, etc.) in DOS Area of the PC card can be loaded into Buffer RAM. The program data in Buffer RAM can be stored in a PC card as a new file. The modified data deployed to Buffer RAM, which is modified on the flash writer can be loaded or saved as a "modified file."

5.9.1 Loading Files

DOS files on the PC card can be loaded into Buffer RAM. Files with an extension "HEX" are recognised as hex files, and files with an extension "S", as Motorola S-format files.

The format (extension Intel hex or Motorola S-format) is automatically determined and any data after the end OP code is ignored.

The name of the files opened on Buffer RAM is controlled as a current file name of the writer side.

Example of Key Operation

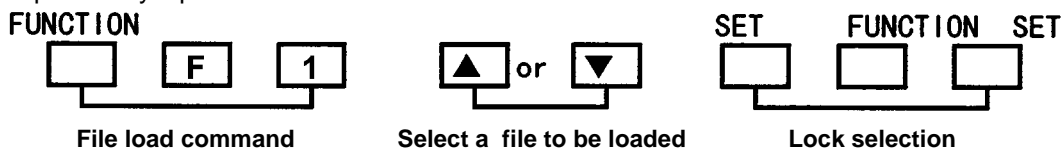

Notes;

- (1) Files with "HEX" or "S" extension as being called by the file load command are original files.

Files with 3-digit numbers for extensions (numbers such as "000," . . . "002," . . . etc.) are the files modified from the original file.

If, for example, the "002" modified file is specified, then the system automatically loads the original file, and loads the "002" modified data.

In this case, "003" and latter modified files are not loaded.

(2) The original file does not necessarily contain the data from all memory areas of the internal flash memory.

Most assembler output data outputs an object file which defines only those addresses in programs or which the data defines.

As a result, the buffer which of the address is defined is updated by the file load. The contents of the Buffer memory does not change before and after the loading.

The Buffer memory is initialised by the Buffer clear command " **FUNCTION** **2** ."

We recommend to execute the buffer clear command before loading an object file.

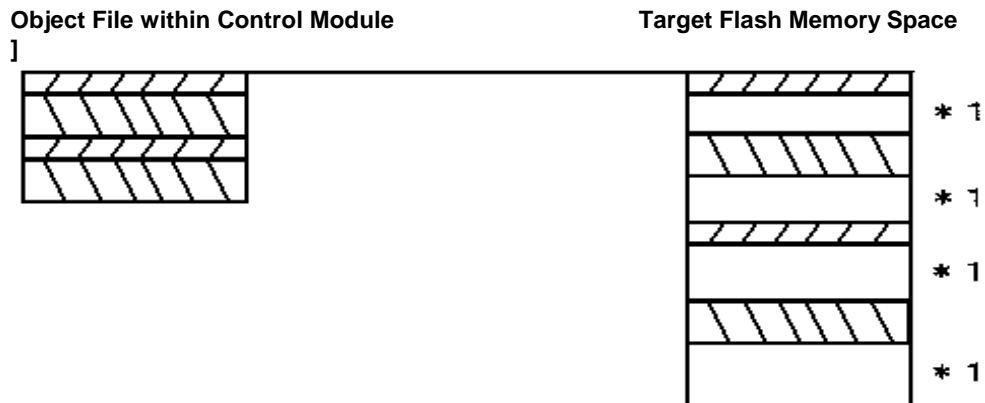

*1 Address areas not defined to the object file are not updated as this object file is loaded (the data before loading remains as it is).

5.9.2 Saving Files

The data in Buffer RAM is saved to PC cards.

Following two file types are generated as the saved data files:

- (1) Full Data Files
If there is no current files, all the data are saved using this format. For example, the program space of the flash micom is read into the writer, it is saved on a PC card as using this format.
- (2) Modified Bit Files
Modified bit files are the modified data file of the original files on Buffer RAM. Only the differentiate data that is saved in the modified file.

Example of Key Operation



File Save Formats

- a. As a current file name already exists.
As a current file name already exists, a new modified bit file name is displayed.
The file name of the modified bit file is automatically created in the format below:

Current File Name . l m n

Current file name: The name of the file loaded by the load command, without extensions.

l m n: Smallest three digit numbers which does not yet exist on the PC card.

To save a new differentiate file, click **SET** **FUNCTION** **SET** .

The original file itself cannot be resaved.

The time data for the modified file is that the time the original file is created plus l m n seconds. (Note; this does not mean that the time recorded for the file is the time when the file is actually created.)

Normally Intel HEX file and Motorola S file formats are not mixed on the same PC card, if there are two files with the same name but two different extensions (.HEX and .S), the file, having a same extension as the format defined by FUNCTION 5, is considered as the original file.

- b. As a current file name does not exist.
 If there is no current files such as when the data is loaded from the target memory, it can be saved into a file with an empty file name and with data length "0."
 The entire target memory can not be saved into the file which is already saved.

Example of Key Operation

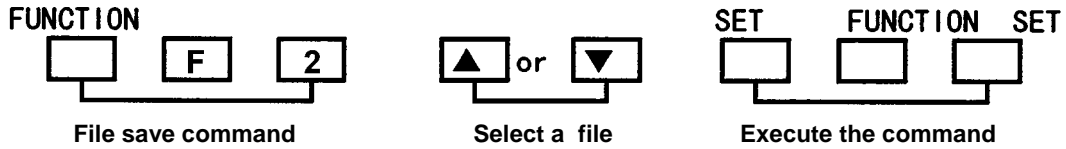

5.9.3 Purging Files

Purges (deletes) files on a PC card.

Example of Key Operation

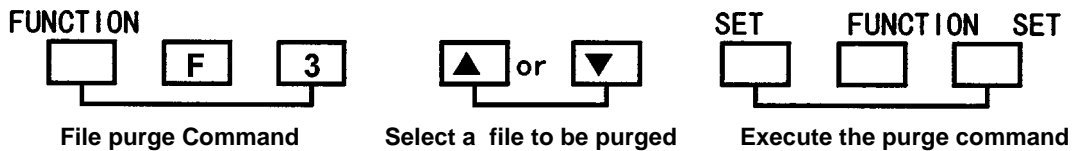

Following messages are displayed on LCD after the key operation above:

PURGE OK?
 Click **SET** key to execute the purge command.
 Click **RESET** key to exit this function without executing the purge command.

5.9.4 Setting the Transfer Address

Specify the Buffer memory address which is a data transfer destination or source as loading or saving a file to the PC card.

As loading an Intel HEX or Motorola S format files, contents set by **FUNCTION** **F** **5** are ignored. (Since the transfer address is recorded in the object file.)

As transmitting serial data, use the address set by **FUNCTION** **F** **5** for addresses of data transmission destination and source.

5.10 Other Functions

Following functions are provided to set up the user environment of AF200.

5.10.1 Setting the Operating Environment of AF200

(1) Buzzer ON / OFF

Example of Key Operation

FUNCTION		SET		FUNCTION SET	
<input type="checkbox"/>	<input type="checkbox"/> 9	<input type="checkbox"/> 1	<input type="checkbox"/>	<input type="checkbox"/>	<input type="checkbox"/>

Turns on and off the buzzer of the flash writer main unit.
Each time this command is executed, the buzzer ON / OFF state changes.
The buzzer is automatically turned on as the main unit is switched on.

(2) Current File Name Display Displays the name of a current file.

Example of Key Operation

FUNCTION		SET		FUNCTION SET	
<input type="checkbox"/>	<input type="checkbox"/> F	<input type="checkbox"/> 4	<input type="checkbox"/>	<input type="checkbox"/>	<input type="checkbox"/>

As this command is executed, the file name of the data sent to Buffer RAM from the PC card is displayed.

5.10.2 Setting the Target Interface Environment

Following functions are for the target micom environment.

(1) Setting Communication Interface

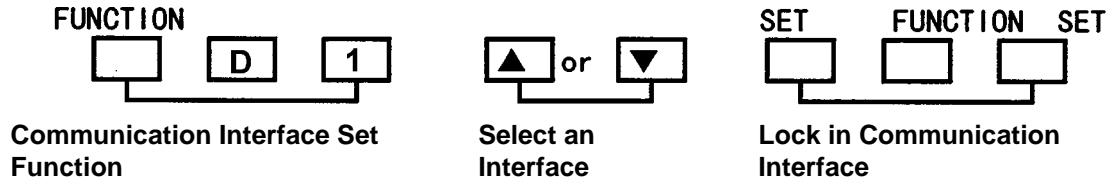

This function is used for selecting and specifying a communication interface for the micom to be programmed from various communication interfaces prepared for communication between the micom and the flash writer.

This function is not defined for micom with only a single communication interface.

FUNCTION
As clicking **D** keys, the current communication interface name is displayed on the "ADDRESS" display part.

U A R T :UART mode

S C I :SCI mode

Use and keys to select a communication interface.

As selecting UART Interface, set as follows:

FUNC D2 → UART baud rate
D7 → Communication channel number

As selecting CSI Interface, set as follows:

FUNC D9 → CSI communication speed
D7 → CSI communication channel number.

(2) Setting UART Communication Speed

This function sets the UART baud rate as UART is selected for the communication channel with the target.

Example of Key Operation

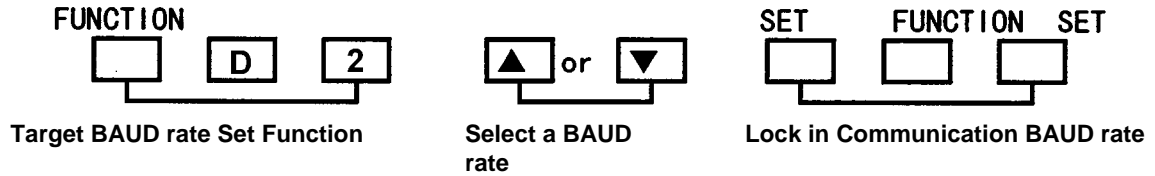

The flash writer supports following BAUD rates:

UART: 2400, 48,00, 9600, 19200, 31250, 38400, 57600, 62500, 75800
CSI: 62.5K, 125K, 250K, 500K

The BAUD rate selected varies depending on a target MCU.

The baud rate selected by **FUNCTION** **D** **2** is displayed on the "ADDRESS" display part.

Example:

		2	4	0	0
--	--	---	---	---	---

 : 2400bps

Use

--

 and

--

 keys to select a communication BAUD rate.

(3) Setting TVcc Threshold

Example of Key Operation

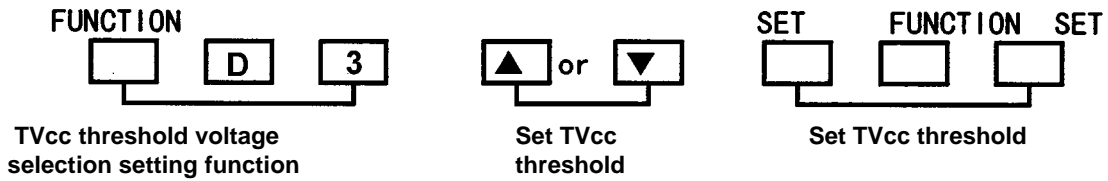

AF200 detects the specified operating voltage applied to the target system and starts executing the device function (such as programming).
TVcc threshold voltage (TVccth) is a requirement target system-side operating voltage at which the device function can execute.

If the power supply voltage of the target system exceeds TVcc threshold after specifying the device command execution start, the specified device function starts executing.
Once the device function starts, it is not cancelled even if the target system power supply voltage falls lower than this TVccth value.

Note: At the point TVcc falls lower than TVccp, the device function is terminated and so is Vpp voltage supply.

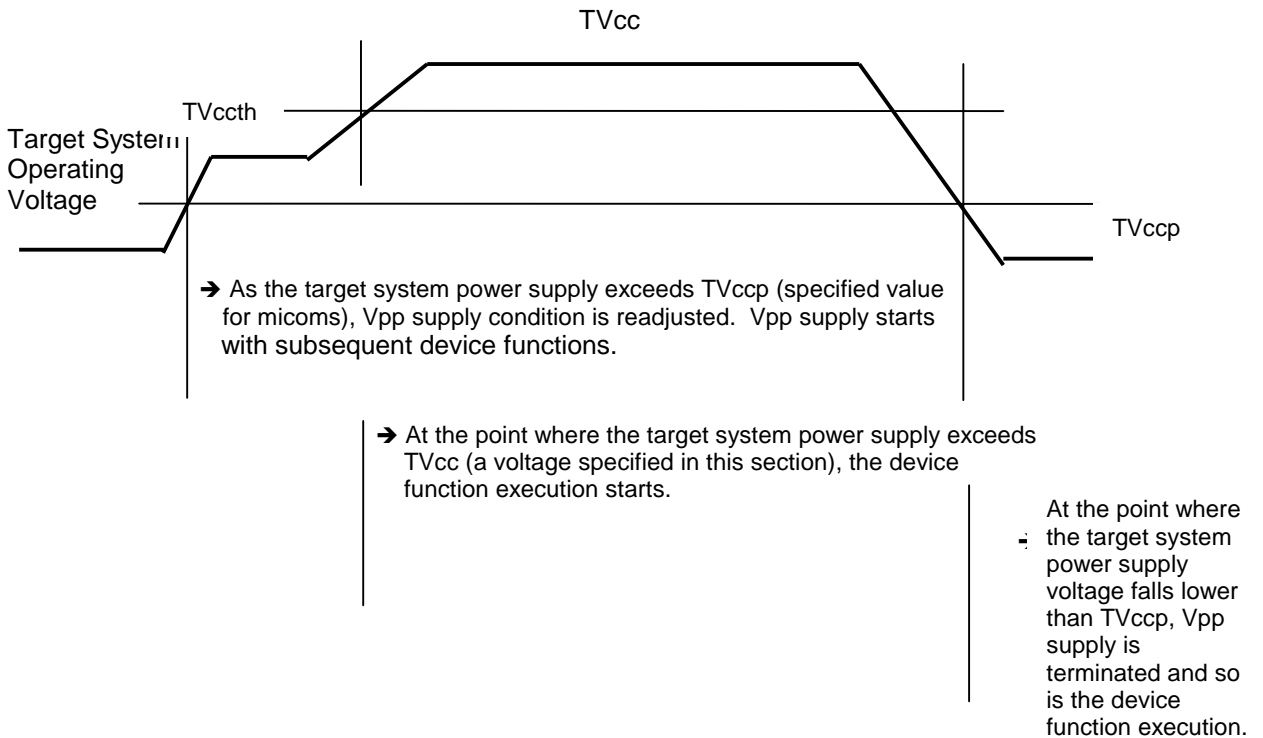

(4) Selecting Target MCU Mode

This function can be used to select a mode for reading and programming.

Example of Key Operation

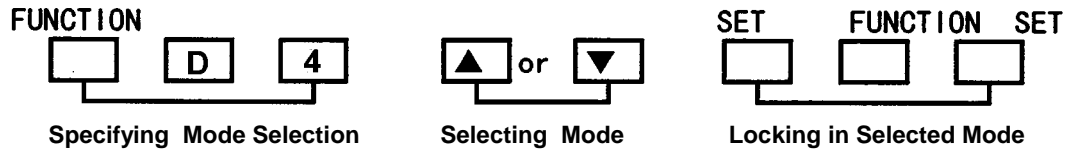

The mode selected currently is displayed on the "ADDRESS" display part by

FUNCTION [] **D** [] **4** .
Use [] and [] keys to select a mode.

The selected mode can be changed by **SET** **FUNCTION** **SET** .
The contents of modes displayed varies depending on a target micom. Refer to each control module manual.

(5) Setting Watchdog Timer Interval

AF200 is provided with a pulse output to the watchdog timer circuit on the target system while writing to or reading from the flash memory.

Example of Key Operation

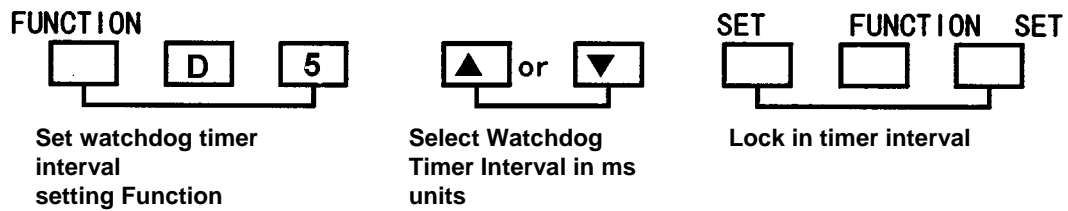

(6) Flash Memory Area Display

It displays the first address and the last address for the internal flash memory of the target micom.

With AF200, the first and the last addresses can be displayed and confirmed.

Also the first and last addresses can be modified as an appropriate control module is installed in the PCMCIA socket of the PC.

Example of Key Operation

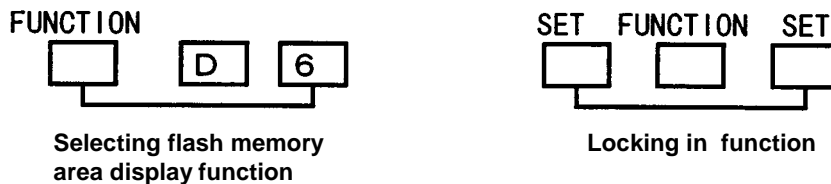

As clicking , the first address (lower limit address) of the internal flash memory area is displayed.

Use and keys to switch the display to the last address display.

With many flash micoms, it is necessary to change the block structure as well as the internal flash memory. (Refer to the each micoms' specification regarding the flash memory block structure.)

AF200 contains flash memory block data with formats described below.

As changing the block structure, use a remote controller / parameter generator software (sold separately) because the large number of data modification.

Block Data Table

The block data table consists of following three data : Block Group Number, Block Group Start Address, and Block Size.

Block Group No:

14 types of blocks can be specified (Type 1 to Type 14). The blocks which are contiguous and have the same size are considered as one block group, and the lower block number is assigned to a block with lower address and the number.

Group Start Address:

The start address for the block group. The flash memory sized by the block size is arrayed contiguously from this address, forming a one block group.

Block Size:

With AF200, the flash memory block defined by this block size is located continuously till the next block group address.

Put "0" on the group start address and block size of the last block.

Example:

Block Group No.	Group Start Address	Block Size
1	#00F80000	#00008000
2	#00FA0000	#00010000
3	#00000000	#00000000

Block Start Address

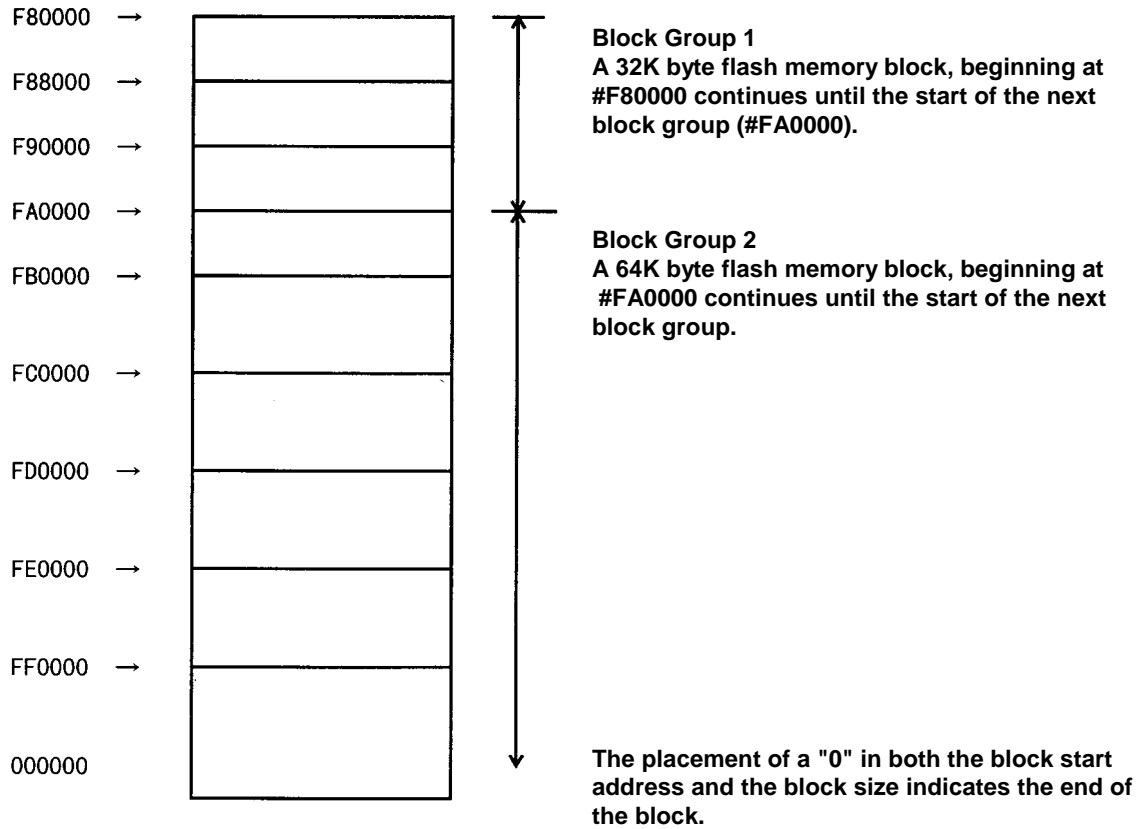

(7) Selecting Communication Channel Number

This function is used to select a communication channel number used between the flash writer and the target micom.

Use **FUNCTION** **D** **7** keys to select a channel number for the communication channel.

Example of Key Operation

Set a channel number by clicking **FUNCTION** **D** **1** .
The channel number is displayed on the "ADDRESS" display part.

Use and keys to select a channel to be used.

Use **SET** **FUNCTION** **SET** keys to lock in the channel number.

(8) Setting and Displaying Display Model Name

This function is for displaying the modified contents of the model number display at the upper left of LCD.

Use **FUNCTION** **D** **8** keys to display the model number on the "ADDRESS" display part.

Use and keys to select a character to be modified.

Use **0** to **F** keys to input the modified contents to the selected character to be modified.

Note; As using the flash writer, the data can be input only with numbers or letters between 0 and F.

The modification with alphanumeric characters can be input as using a software (sold separately) which operates by PC /AT.

(9) Setting CSI Communication BAUD Rate

This function sets the CSI communication BAUD rate used as using the CSI communication channel of the target micom.

Example of Key Operation

FUNCTION

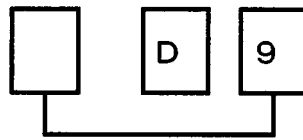

**Selecting a CSI communication
BAUD rate set function**

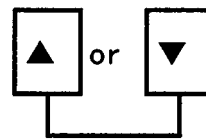

**Selecting a CSI
communication BAUD rate**

Use and keys to select a communication baud rate.
The selected communication baud rate is displayed in the "ADDRESS" display part.

Use **SET** **FUNCTION** **SET** keys to lock in the communication baud rate.

6. Remote Control

AZ290: Remote Controller (a software operates on Windows 95 and NT) is available as an option (Sold separately) .

We offer Remote Controller Version for an evaluation, on our home page.

Parameters in the control module can be easily modified through a remote controller. Refer to AZ290 Users Manual (on our home page) for further details.

(2) PCMCIA Card Interface

a. PCMCIA card is used in following two areas:

- * DOS Area
To store users' object program files.
- * Non-DOS File Area
A control program (definition part) is stored. (approximately 300 K bits)
Since this program contains a data to control programming, NEVER modify this data.
This area can not destroyed by accessing with normal DOS file formats.

b. Formatting PC Cards

Do not format control modules by yourself.

(3) Target Interface

a. Vpp Output Voltage and its Current

The programming voltage and output characteristics for AF200 are as shown below:

Vpp	Ipp max.
0 V to 3.0 V (+/- 5%)	10 mA
3.0 V to 12.5 V (+/- 5%)	200 mA

b. TVcc Range

This unit can be used with micoms operating in a range of TVcc = 3 V (- 10%) to 5 V (+ 5%).

c. Target Interface Connector and Target Probe

The probe-side connectors fit with target interface connector gate probes of AF200 are as follows:

DX40-28P (Hirose)

DX-28-CV (cover)

Each target probe has each own feature for each control module. Please use an appropriate probe.

Modifying probes or using an inappropriate probe may result in a serious damage to AF200 or the target system. Be sure to use a proper probe correctly.

(4) External Dimensions

210 (L) x 148 (w) x 44 (H)

8. Commands

The following chart shows the function and device function commands.

8.1 Function Commands

The function commands can be selected by clicking .

* Function			
Item	Function Name	n	Chapter to refer
1	Address Set	0	5.3
2	Block Store	1	5.6.1
3	Modify Bit Search	3	5.6.1
4	Serial Input	4 1	5.7
5	Serial Output	4 2	5.7
6	Data Format	5	5.7.4
7	Serial Interface Set	7	5.7.6
	AUX	8X	Refer to Control Module Users Manual Chapter 3 *1
8	Buzzer ON / OFF	9 1	5.10.1 (1)
9	Remote / Local	9 2	5.8.2
13	Target UART/CSI	D1	5.10.2 (1)
14	UART Communication Speed Select	D2	5.10.2 (2)
15	TVcc Threshold	D3	5.10.2 (3)
16	Target MCU Mode Select	D4	5.10.2.(4)
17	Watchdog Timer	D5	5.10.2 (5)
18	Internal Area Display	D6	5.10.2 (6)
19	Communication Channel Select	D7	5.10.2 (7)
20	Modifying Display Model no.	D8	5.10.2 (8)
21	CSI Communication Speed Select	D9	5.10.2 (9)
22	Application Read ON / OFF	DA	As an option
23	Application Read Wait Set tB	DB	As an option
24	Application Read Wait Set tC	DC	As an option
25	Application Read Wait Set tD	DD	As an option
26	Application Read Wait Set tE	DE	As an option
27	AUX Set	DF	Refer to Control Module Users Manual Chapter 3 *1
28	File Load	F1	5.9.1
29	File Save	F2	5.9.2
30	File Purge	F3	5.9.3
31	Current File Display	F4	5.10.1 (2)
32	Transmission Address Set	F5	5.9.4
33	Buffer Clear	2	5.6.2 (2)

*1 These are the specific functions for the control module. Not all the control modules support these function.

8.2 Device Function Commands

The device function can be selected by clicking .

* Device Functions

Item	Function Name	No.	Display	Details
1	Copy Read Check	8	COPY	Copy from the device to Buffer RAM and execute Read Check
2	Erase Blank Check	C	ERASE	Erase the device and execute Blank Check
3	Blank Check	9	BLANK	Check the erased state
4	Program *1	D	PRGM	*1
5	Read Check	E	READ	Compares the device and Buffer RAM
6	E P R Continuous Operation	F	E.P.R	Erase, Blank Check, Program and Read Check

*1 Details of Program differs depending on each control module. Refer to each control module manual or contact YDC Support Centre or your local distributors.

9. Error Codes

AF200 has each error detection function.
Error messages to be displayed are shown below.

No.	Error Code List	Description	Reference
01	WORK RAM ERR	Working RAM Error	Defective AF200 Defective control modules Defective AF200
02	BUFF RAM ERR	Buffer RAM Error	
03	PROG ROM ERR	Program ROM Error	
04	PC CARD ERR	PC card program Error	
15	TVcc TOO LOW	TVcc is lower than the threshold value	(1) Either the user system itself or a defective connection with the user system (2) or an incorrect operation
16	VPP1 TOO LOW	Vpp1 is lower than the pre-set value	
17	Vpp2 TOO LOW	Vpp2 is lower than the pre-set value	
18	DEV: CRC REPLY	Device communication Error: No Response	
19	DEV: CRC ERR	Device communication Error: Parity Error	
1A	DEV: OVERRUN	Device communication Error: Overrun Error	
1B	DEV: FRAMING	Device communication Error: Framing Error	
20	COM: I/O ERR	Serial I/O circuit open or Break State	Defective Host Communication
21	COM: IN ERR	Serial input parity or similar error	
22	COM: OUT ERR	Serial Output Time-out (5 seconds)	
33	FORMAT ERR	Transmission format Error	During file load or serial input Address register overflow
34	ADDRESS ERR	Address Error	
35	FILE CRC ERR	Sum check Error	
36	HEX OVERFLOW	Intel format Overflow	
40	INVALID CARD	PC CARD: Invalid Format Error	Checked as a PC card is inserted
42	WR PROTECTED	PC CARD: Write Protected	
43	BATTERY EMPTY	PC CARD: Battery Empty	
44	CARD PMT ERR	PC CARD: Parameter Error	
50	DISK FULL	Disk full error	Determined as programming to files
60	FILE FMT ERR	File format Error	
62	MDFY# FULL	Modified file address Full	
63	NEW FILE ERR	File creation Error	
E1	FILE OPN ERR	File open Error	

Standard Probe A (AZ210)

AZ210 target probe assembly is a AF200 standard probe cable.
 AZ210 connector diagram is as shown below.

Refer to each control module manual regarding each signal definitions for each control module.

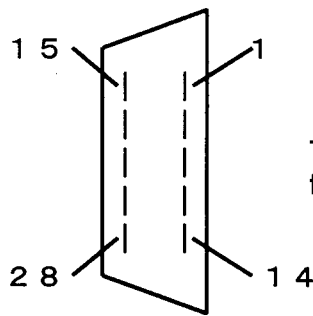

The pin layouts are viewed from the cable side.

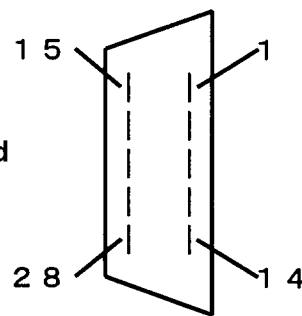

D X 3 1 A 2 8 P

D X 3 1 A 2 8 P

15	1
16	2
17	3
18	4
19	5
20	6
21	7
22	8
23	9
24	10
25	11
26	12
27	13
28	14

AF200 Standard Signal Name				
	GND	15	1	GND
	TVpp1	16	2	TVcc
	TVpp2	17	3	Vcc
	WDT	18	4	TRES
	TVpp1C	19	5	/TRES
	TVpp2C	20	6	TCK
	GND	21	7	GND
	GND	22	8	GND
	AUX	23	9	TRW
	TBUSY	24	10	/TICS
	TI0	25	11	/TOE
	TI1	26	12	TMODE
	TRXD	27	13	TTXD
	GND	28	14	GND

One to One Cable (full 28 pin-to-pin wired) AZ210 Pin Connection

The connector to be mounted on the user system (the target board) are as follows.
 DX10-28S (right-angle type) manufactured by Hirose

Appendix 1

Standard Probe B (AZ211) and D (AZ213)

AZ211 has test clips on the target side.

This probe is for testing in labs.

AZ213 has no test clips. Connect to an appropriate connector to the micom by users.

Test Clip Colour	CN100	AF200 Standard Signal Name				CN100	Test Clip Colour
	*	GND	15	1	GND	*	
Light-Green	19	TVpp1	16	2	TVcc	20	Light-Blue
White & Violet	17	TVpp2	17	3	Vcc	18	White & Grey
White & Green	15	WDT	18	4	TRES	16	White & Blue
White & Orange	13	TAUX3 TVpp1c	19	5	/TRES	14	White & Yellow
White & Brown	11	TAUX4 TVpp2	20	6	TCK	12	White & Red
	*	GND	21	7	GND	*	
	*	GND	22	8	GND	*	
White	9	TAUX	23	9	TAUX2 (TR/W)	10	White & Black
Violet	7	TBUSY	24	10	/TICS	8	Grey
Orange	3	T10	25	11	TAUX5 (/TOE)	6	Blue
Green	5	T11	26	12	TMODE	4	Yellow
Brown	1	TRXD	27	13	TTXD	2	Red
	*	GND	28	14	GND	*	

AZ211 Pin Connection

* : GND Line (Black) is directly soldered to PWB.

Standard Probe C (AZ212)

Standard Probe C (AZ212) is used with a customer modification.
Use with your specific connector.

1. Physical Specification

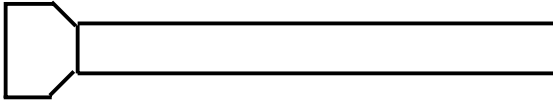

2. Wiring Specification

Dot Mark Red	Insulator Colour	AF200 Standard Signal Name				Insulator Colour	Dot Mark Black
	Orange	GND	15	1	GND	Orange	
	Grey	TVpp1	16	2	TVcc	Grey	
	White	TVpp2	17	3	Vcc	White	
	Yellow	WDT	18	4	TRES	Yellow	
	Pink	TAUX3 TVpp1c	19	5	/TRES	Pink	
	Orange	TAUX4 TVpp2c	20	6	TCK	Orange	
	Grey	GND	21	7	GND	Grey	
	White	GND	22	8	GND	White	
	Yellow	TAUX	23	9	TAUX2 (TR/W)	Yellow	
	Pink	TBUSY	24	10	/TICS	Pink	
	Orange	T10	25	11	TAUX5 (/TOE)	Orange	
	Grey	T11	26	12	TMODE	Grey	
	White	TRXD	27	13	TTXD	White	
	Yellow	GND	28	14	GND	Yellow	

AZ212 Pin Connection